



# ELECTRIC FORSAIRE™ COUNTERFLOW FURNACES



The electric Forsaire is the practical choice for those areas where natural or propane gas installation is not convenient. Providing low-cost, floor-to-ceiling comfort and easy installation, this totally automatic, thermostat-controlled (*sold separately*) furnace is ideal for heating one or two rooms.

Freestanding or recessed, this furnace is at home almost anywhere and the decorator styling with a scratch-resistant, soft-white finish will complement any decor.

## FEATURES

- Freestanding or recessed, Electric Forsaire Furnaces are ideal for homes, apartments, offices, schools, cabins and many other applications.
- CSA listed
- Heating capacity of 31,400 BTU/hr.
- Multi-room heating with optional outlet kits
- Attractive decor, scratch and abrasion resistant powder-coat, soft-white finish
- Counterflow blower system circulates ceiling-to-floor warm air
- Occupies less than one square foot of floor space
- Automatic fan controls and safety devices

ELECTRIC FORSAIRE COUNTERFLOW  
31,400 BTU/hr.



DESIGNED  
& ASSEMBLED  
IN THE USA  
SINCE 1916

# ELECTRIC FORSAIRE COUNTERFLOW FURNACES

MODEL NO.	kW INPUT	HEATING OUTPUT BTU/hr.		OPERATING VOLTAGE MIN - MAX	DIMENSIONS INCHES			CFM 115V	CIRCUIT AMPS	DISCHARGE AIR TEMP AT 240V	SHIP WEIGHT LBS.
		@240V	@208V		WIDTH	DEPTH	HEIGHT				
3144030	9.2	31,400	23,600	207 - 253	14 1/8	7	72 1/2	375	50	80° F RISE	60

## FEATURES

All wiring and controls are easily accessible from the front. Transformer, terminal block, relay and motor are factory pre-wired with thermostat wires pigtail outside. The total system plus individual elements are protected by safety limit switches.

### CONTEMPORARY FINISH

Soft-white, powder-coated, high-heat resistant finish to complement any decor.

### BLOWER SYSTEM

Powerful, lint-free patented peripheral blower system and heavy-duty motor combine to deliver warm air smoothly and quietly on vibration-free mountings. Blower features a self-cleaning air scoop design. Motor, collid by a centrifugally swept air-stream, is equipped with self-aligning porous bearings. no filter is required.

### DIMENSIONS AND CLEARANCES

6" to an intersecting wall  
0" to finished floor

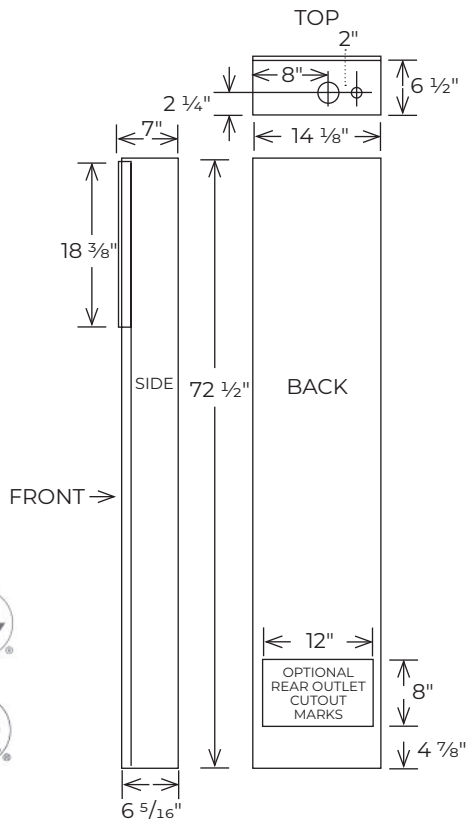

**WARNING:** This product can expose you to chemicals including epichlorohydrin which is known to the State of California to cause cancer and birth defects and/or other reproductive harm. For more information go to [www.p65warnings.ca.gov](http://www.p65warnings.ca.gov)

## ACCESSORIES

**THERMOSTAT SOLD SEPARATELY** part number 8967

### REAR-OUTLET REGISTER

Allows heated air to be delivered to a second room behind the furnace.

**MODEL 6501** Rear-Outlet Register with 10" boot

Shipping weight 7 lbs.

### DIFFUSER GRILLE

A snap-on diffuser grille is available for all models. When warm air discharges from the front, a diffusing grille can be used to divert heat to the right, left or in both directions.

**MODEL 6703** Two-way diffusing grille. Shipping weight 3 lbs

**MODEL 6704** One-way diffusing grille. Shipping weight 3 lbs.

### EASY INSTALLATION

This Forsaire Electric Wall Furnace requires less than one square foot of floor space and provides warm air circulation for maximum comfort.

The 9.2kW input, 31,400 BTU/hr. output model delivers heat into one or two rooms via a large quiet blower. This model may be recessed into the stud space or surface mounted. With a cabinet depth of seven inches, recessed installation provides a projection of only three inches into the living space. A freestanding application solves the problem in otherwise hard-to-heat areas. Totally automatic fan controls and safety devices are factory supplied.

### TYPICAL INSTALLATIONS

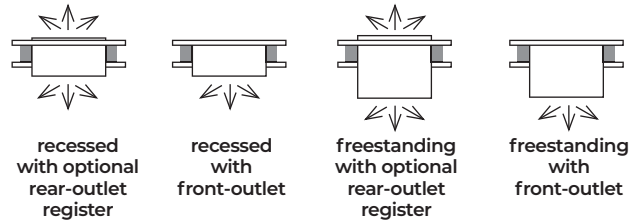

### IMPORTANT

**ANY WARRANTY CONSIDERATIONS ARE CONTINGENT ON INSTALLATION BY A QUALIFIED INSTALLER (CONTRACTOR). SELF-INSTALLATION IS PROHIBITED AND WILL INVALIDATE YOUR WARRANTY.**

- Read owner's manual before using/installing.
- Photographs are representative only.
- Check local codes and ordinances for permitted uses.
- Consult installation manual for clearances prior to installation.
- We reserve the right to amend product specifications without notice.
- Installation and servicing recommended by a qualified service person.
- Please read the warranty for any limitations of disclaimers. Combustion chamber carries a 10-year limited warranty. All other parts carry a one-year limited warranty.