

Drawing is for standard fan coil configuration only. When valve packages or drain pan extensions are added consult fancoils@wfc-fc.com for an "as built" drawing.

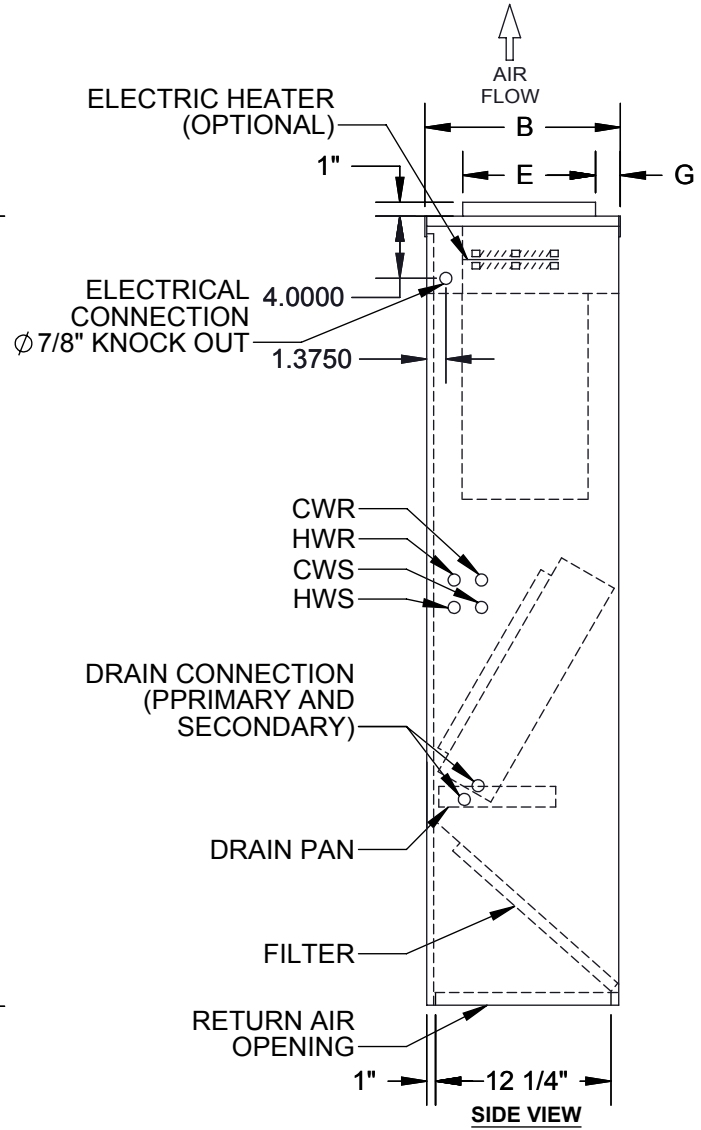

RIGHT HAND SHOWN

MODEL	A	B	C	D	E	F	G	FILTER SIZE
400	20 1/4	14 1/4	57 5/8	10 1/2	7 1/8	2 1/2	4 3/16	(1) 16x16x1
600	20 1/4	14 1/4	57 5/8	10 1/2	8 1/2	2 1/2	2 13/16	(1) 16x16x1
800	20 1/4	14 1/4	57 5/8	10 1/2	9 1/2	2 1/2	1 13/16	(1) 16x16x1

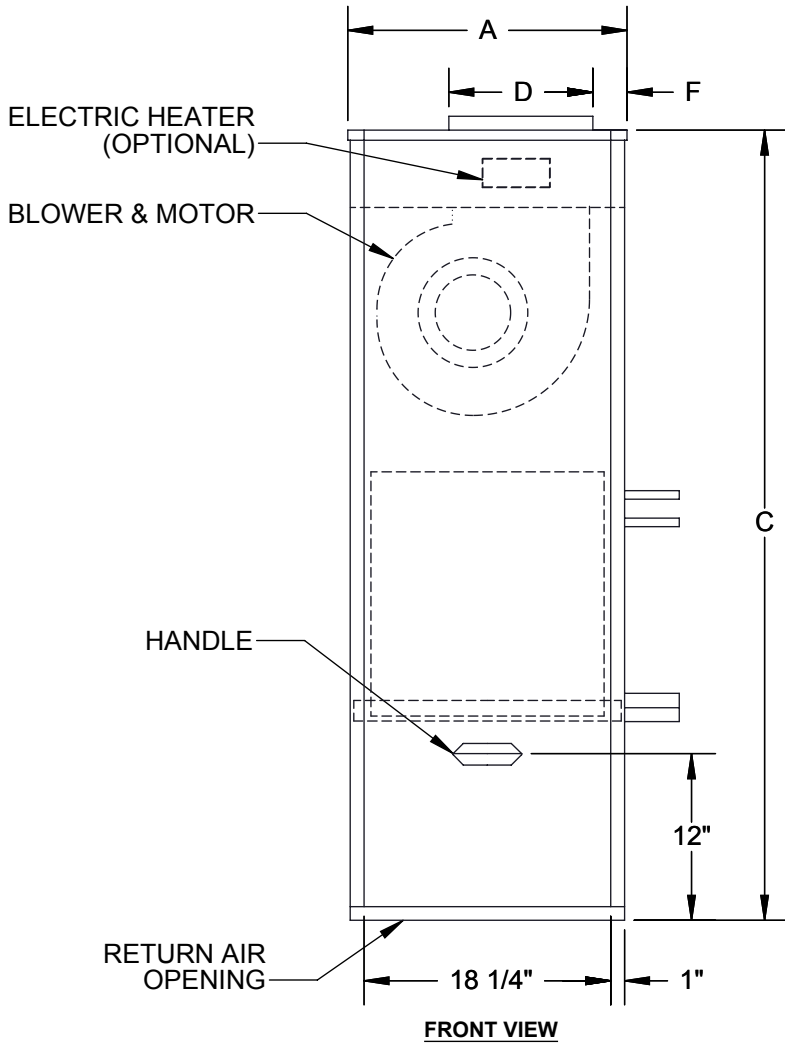
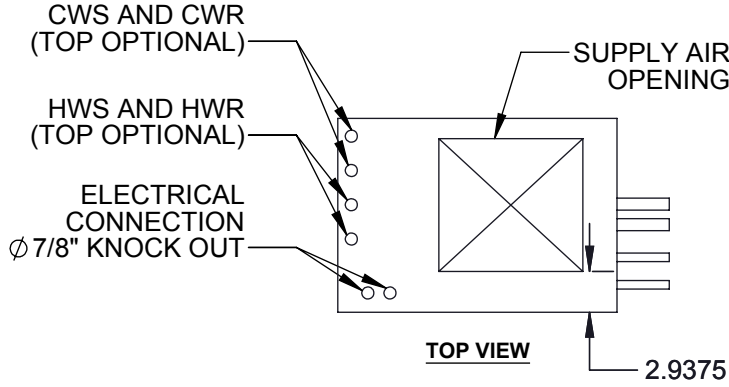
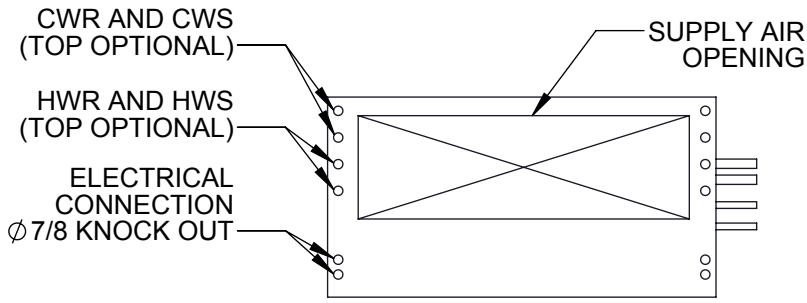

TOP VIEW

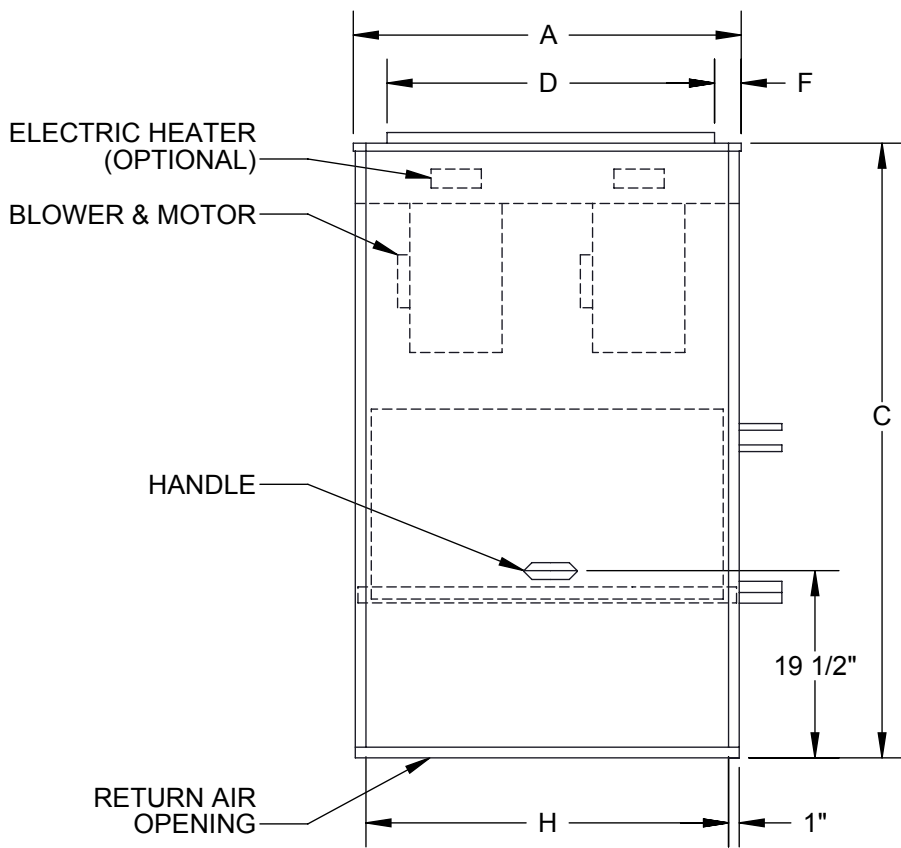

FRONT VIEW

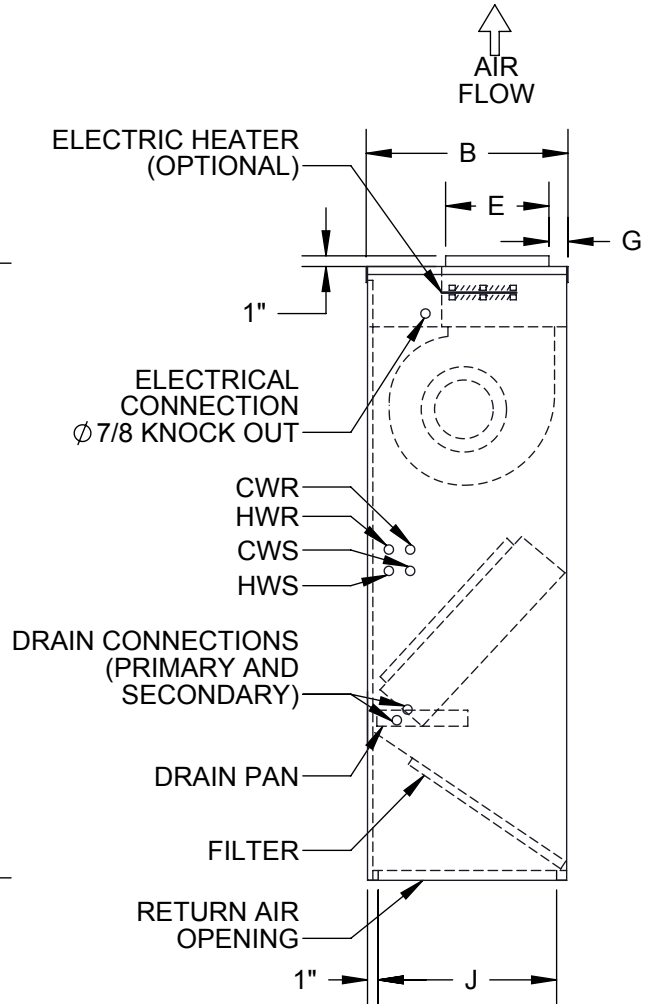

SIDE VIEW

RIGHT HAND SHOWN

MODEL	A	B	C	D	E	F	G	H	J	FILTER SIZE
1000	20 3/8	20 1/4	57 3/4	12	10 3/8	4 1/8	2 3/4	18 3/8	18 1/4	(1) 16x20x1
1200	20 3/8	20 1/4	57 3/4	12	10 3/8	4 1/8	2 3/4	18 3/8	18 1/4	(1) 16x20x1
1500	36	24 5/8	62 3/4	28	10 1/2	4	3	34	22 5/8	(2) 16x20x1
1800	36	24 5/8	62 3/4	28	10 1/2	4	3	34	22 5/8	(2) 16x20x1
2200	36	24 5/8	62 3/4	28	10 1/2	4	3	34	22 5/8	(2) 16x20x1

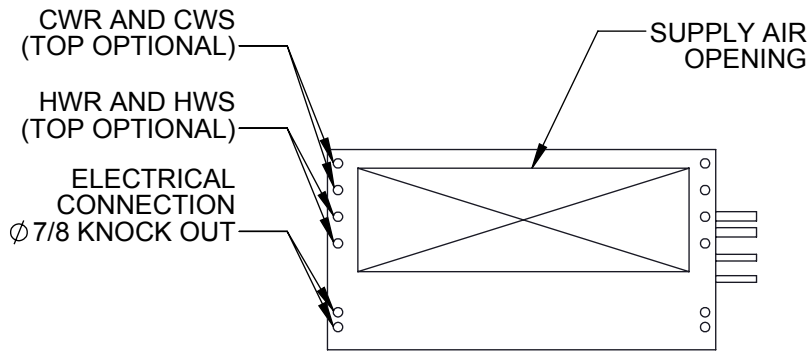

TOP VIEW

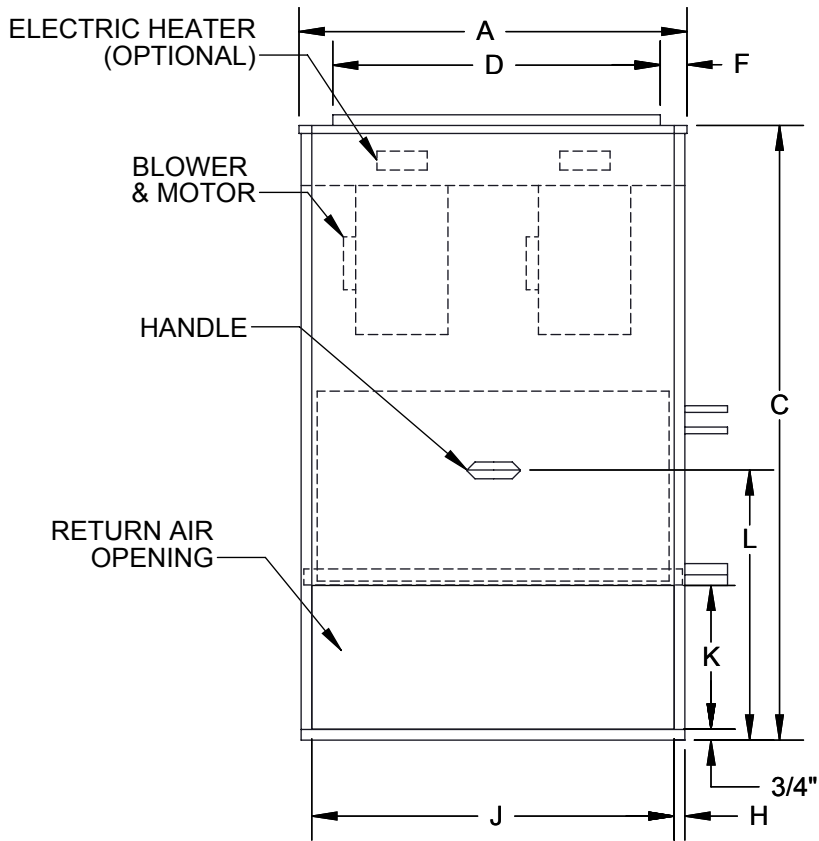

FRONT VIEW

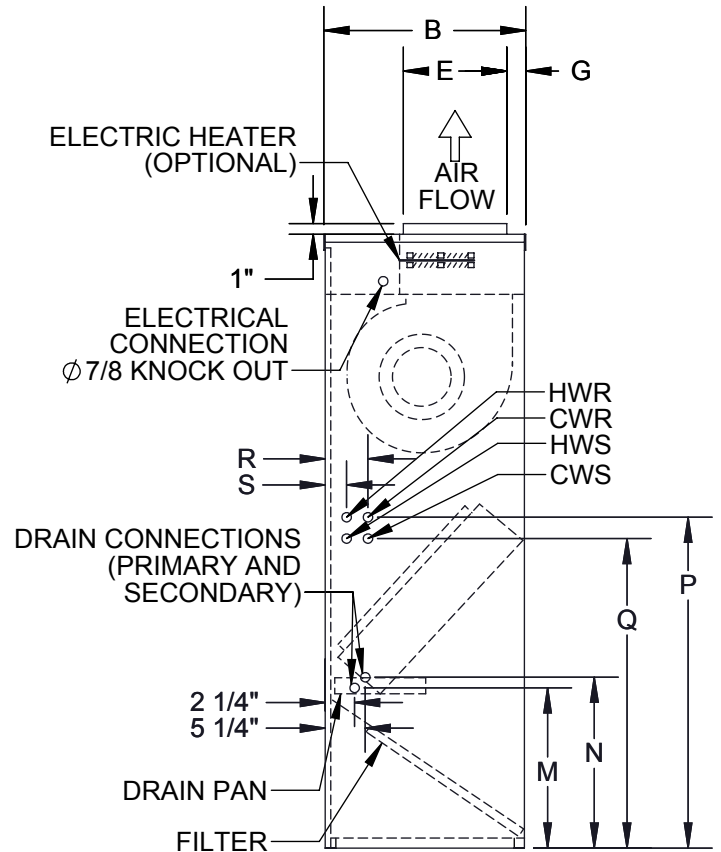

SIDE VIEW

RIGHT HAND SHOWN

MODEL	A	B	C	D	E	F	G	H	J	K	L	M	N	P	Q	R	S	BLOWER/MOTOR	FILTER SIZE
400	20 1/4	14 1/4	57 5/8	10 1/2	7 1/8	2 1/2	4 3/16	1 5/8	18 7/8	11 1/4	16	13 1/8	14	30 15/16	28 15/16	4 11/16	2 9/16	1	(1) 16x16x1
600	20 1/4	14 1/4	57 5/8	10 1/2	8 1/2	2 1/2	2 3/16	1 5/8	18 7/8	11 1/4	16	13 1/8	14	30 15/16	28 15/16	4 11/16	2 9/16	1	(1) 16x16x1
800	20 1/4	14 1/4	57 5/8	10 1/2	9 1/2	2 1/2	1 3/16	1 5/8	18 7/8	11 1/4	16	13 1/8	14	30 15/16	28 15/16	4 11/16	2 9/16	1	(1) 16x16x1
1000	20 3/8	20 1/4	57 3/4	12	10 3/8	4 1/8	2 3/4	1 1/2	17	12 1/4	17 1/8	14 3/4	15 5/8	30 15/16	29	4 1/8	2 1/8	2	(1) 17x22x1
1200	20 3/8	20 1/4	57 3/4	12	10 3/8	4 1/8	2 3/4	1 1/2	17	12 1/4	17 1/8	14 3/4	15 5/8	30 15/16	29	4 1/8	2 1/8	2	(1) 17x22x1
1500	36	24 5/8	62 3/4	28	10 1/2	4	3	1 5/8	32 1/2	13 5/8	19 1/8	15	15 7/8	31	29	4 1/8	2 1/8	2	(2) 16x20x1
1800	36	24 5/8	62 3/4	28	10 1/2	4	3	1 5/8	32 1/2	13 5/8	19 1/8	15	15 7/8	31	29	4 1/8	2 1/8	2	(2) 16x20x1
2200	36	24 5/8	62 3/4	28	10 1/2	4	3	1 5/8	32 1/2	13 5/8	19 1/8	15	15 7/8	31	29	4 1/8	2 1/8	2	(2) 16x20x1

CV-B
REV A
FR RTN TOP SPLY

D107741

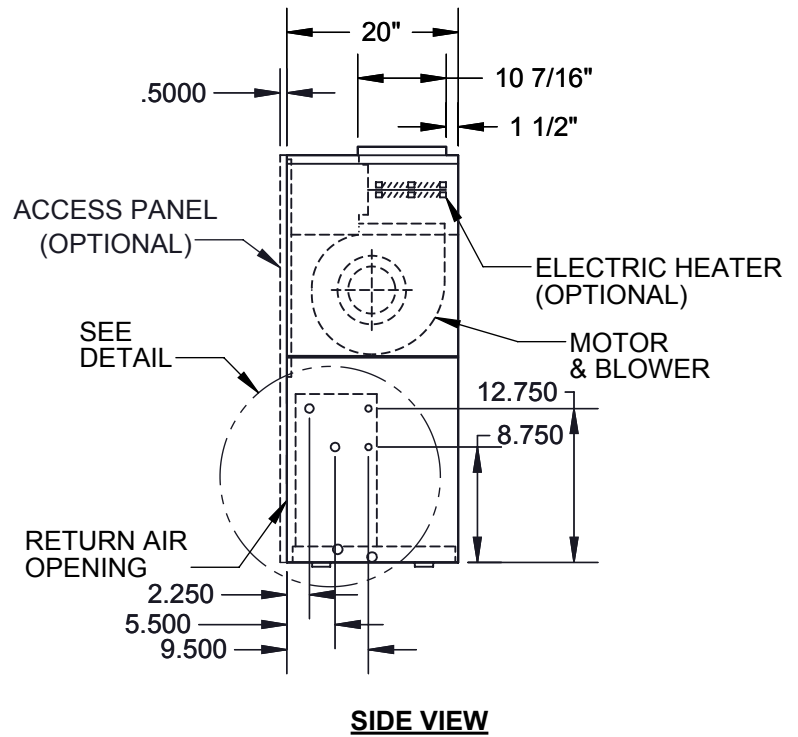
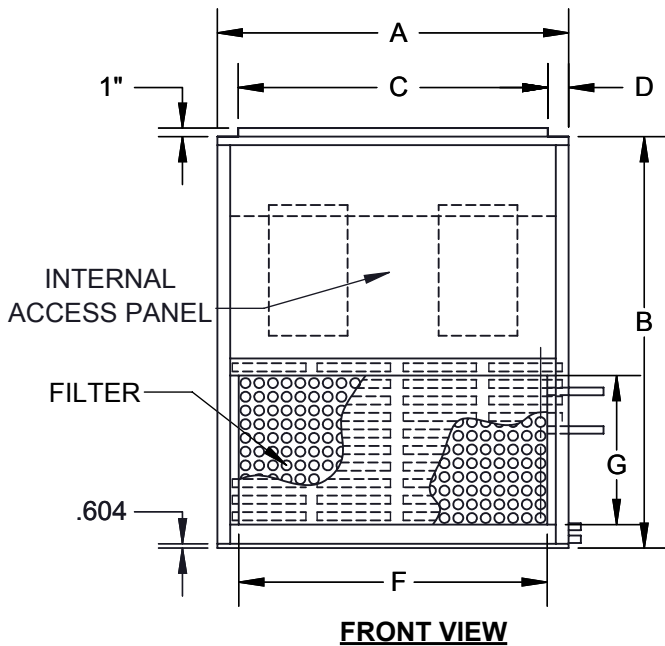
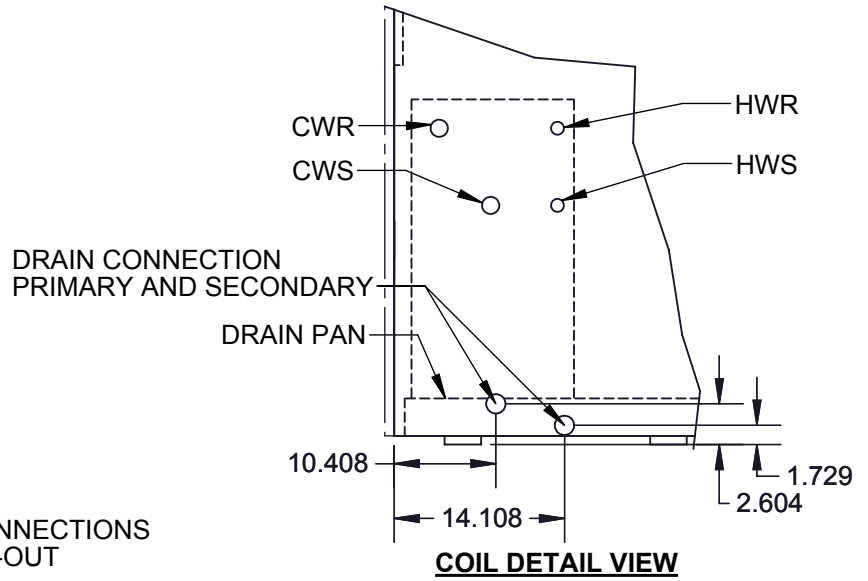
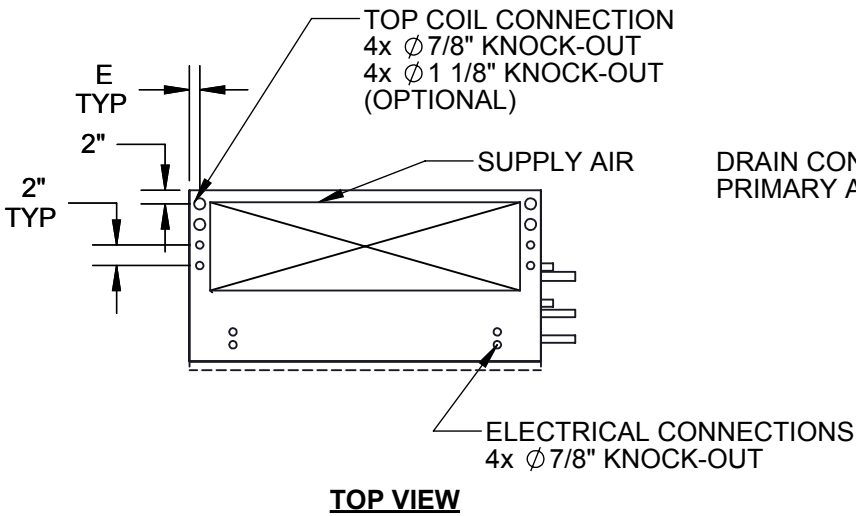

RIGHT HAND SHOWN

MODEL	A	B	C	D	E	F	G	BLOWER QTY	FILTER SIZE
600	21	42	12 1/4	4 3/8	1 1/2	16	14 1/2	1	(1) 16x16x1
800	25	42	12 1/4	6 3/8	1 1/2	20	14 1/2	1	(1) 16x20x1
1000	25	45	12 1/4	6 3/8	1 1/2	20	16 1/2	1	(1) 18x20x1
1200	30	45	12 1/4	8 7/8	1 1/2	25	17	1	(1) 20x25x1
1500	37	48	25 1/4	5 7/8	1 1/2	32	17	2	(2) 16x20x1
1800	37	48	32 1/4	2 3/8	1 1/4	32	18 1/2	2	(2) 16x20x1
2200	41	48	36 1/4	2 3/8	1 1/4	36	18 1/2	2	(1) 16x20x1
									(1)20x20x1

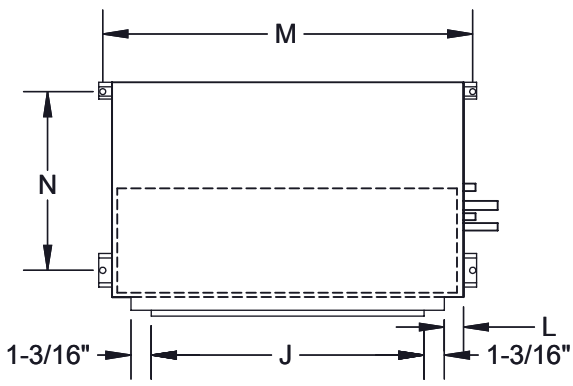

TOP VIEW

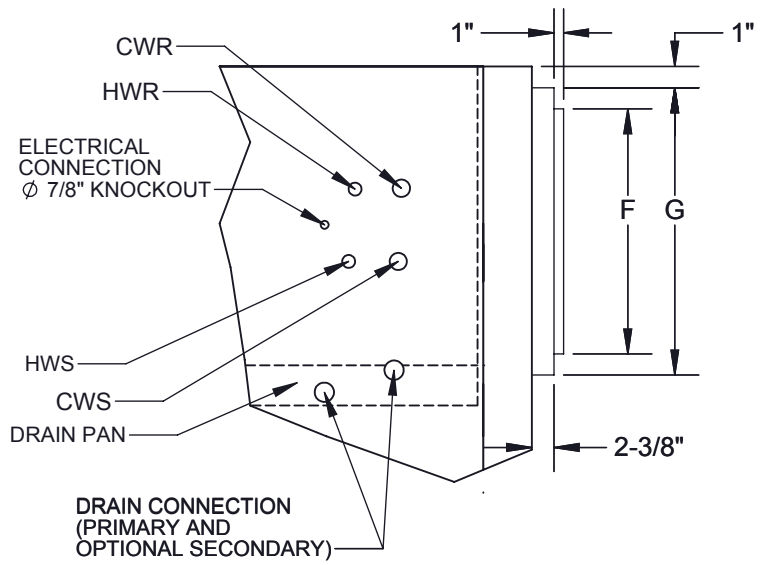

COIL CONNECTION DETAIL

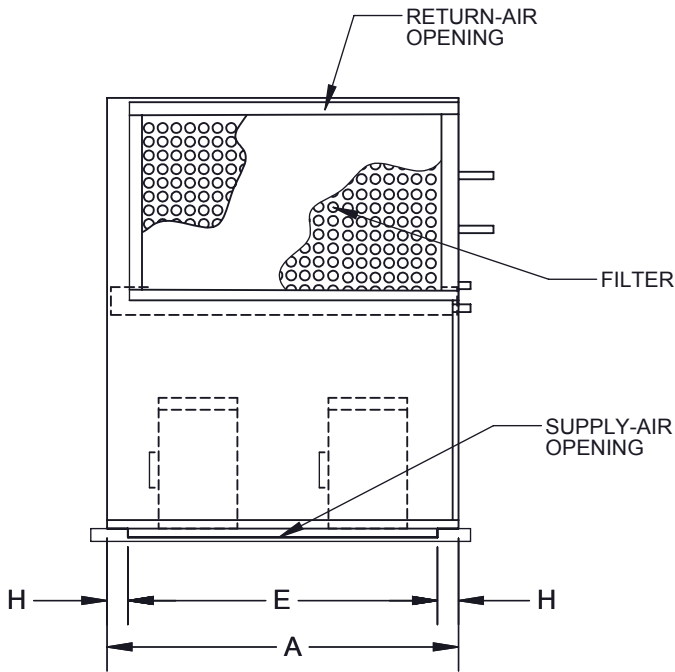

FRONT VIEW

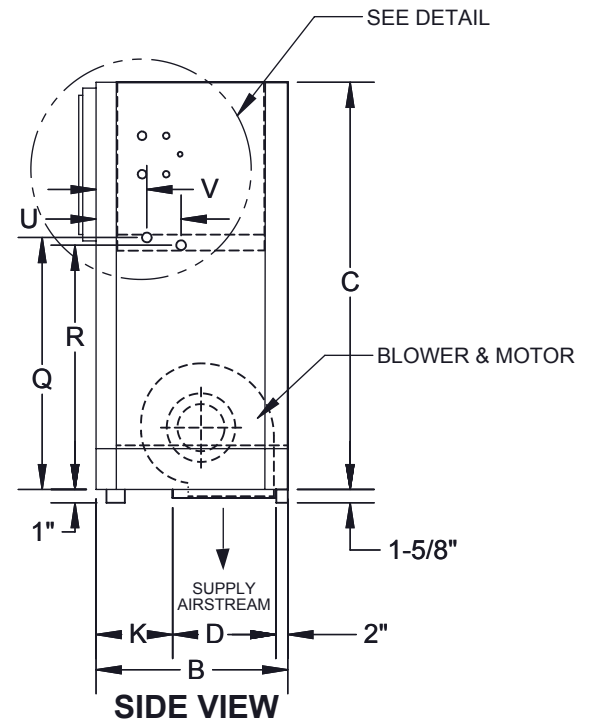

SIDE VIEW

RIGHT HAND UNIT SHOWN

MODEL	A	B	C	D	E	F	G	H	J	K	L	M	N	Q	R	U	V	Blower/ Motor	Filter Size
004-006	24-1/16	27-1/8	46	14	20	17-1/2	20	2-1/32	18	11-1/8	1	26	20-1/4	28-11/16	27-1/2	12	8	1	(1) 16x20x1
008	24-1/16	27-1/8	46	14	20	17-1/2	20	2-1/32	18	11-1/8	1	26	20-1/4	28-11/16	27-1/2	12	8	1	(1) 16x20x1
010	30-1/16	27-1/8	46	14	20	17-1/2	20	5-1/32	23	11-1/8	1	32	20-1/4	28-11/16	27-1/2	12	8	1	(1) 20x20x1
012	30-1/16	27-1/8	46	14	20	17-1/2	20	5-1/32	23	11-1/8	1	32	20-1/4	28-11/16	27-1/2	12	8	1	(1) 20x25x1
015	38-1/16	27-1/8	46	16	22	17-1/2	20	8-1/32	29-11/16	9-1/8	1-3/8	40	20-1/4	28-11/16	27-1/2	12	8	2	(2) 16x20x1
018	38-1/16	27-1/8	54	18	24	17-1/2	20	7-1/16	29-11/16	7-1/8	1-3/8	40	20-1/4	34-5/16	33-1/8	12-1/8	8-1/8	2	(2) 16x20x1
022	46-18	27-1/4	60	20	30	22-9/16	25	8-1/8	37-11/16	5-1/4	1-3/8	48	20-1/2	34-5/16	32-1/16	12-1/8	8-1/8	2	(1) 16x20x1 (1) 20x20x1

CV-G/CV-Q
REV A

D107778

- Coil connections determined by facing the supply-air opening.
- Electrical junction box is located on the same side as the coil connections.
- Unit must be installed level and condensate drain lines should be trapped.